

COIL FORMER  
General data 8-pins RM6 coil former

PARAMETER	SPECIFICATION
Coil former material	polyamid (PA66), glass reinforced, flame retardant in accordance with "UL 94HB"; UL file number E41938
Pin material	copper-tin alloy (CuSn), tin (Sn) plated
Maximum operating temperature	130°C, "IEC 60085", class B
Resistance to soldering heat	"IEC 60068-2-20", Part 2, Test Tb, method 1B, 350 °C, 3.5 s
Soldeerability	"IEC 60068-2-20", Part 2, Test Ta, method 1

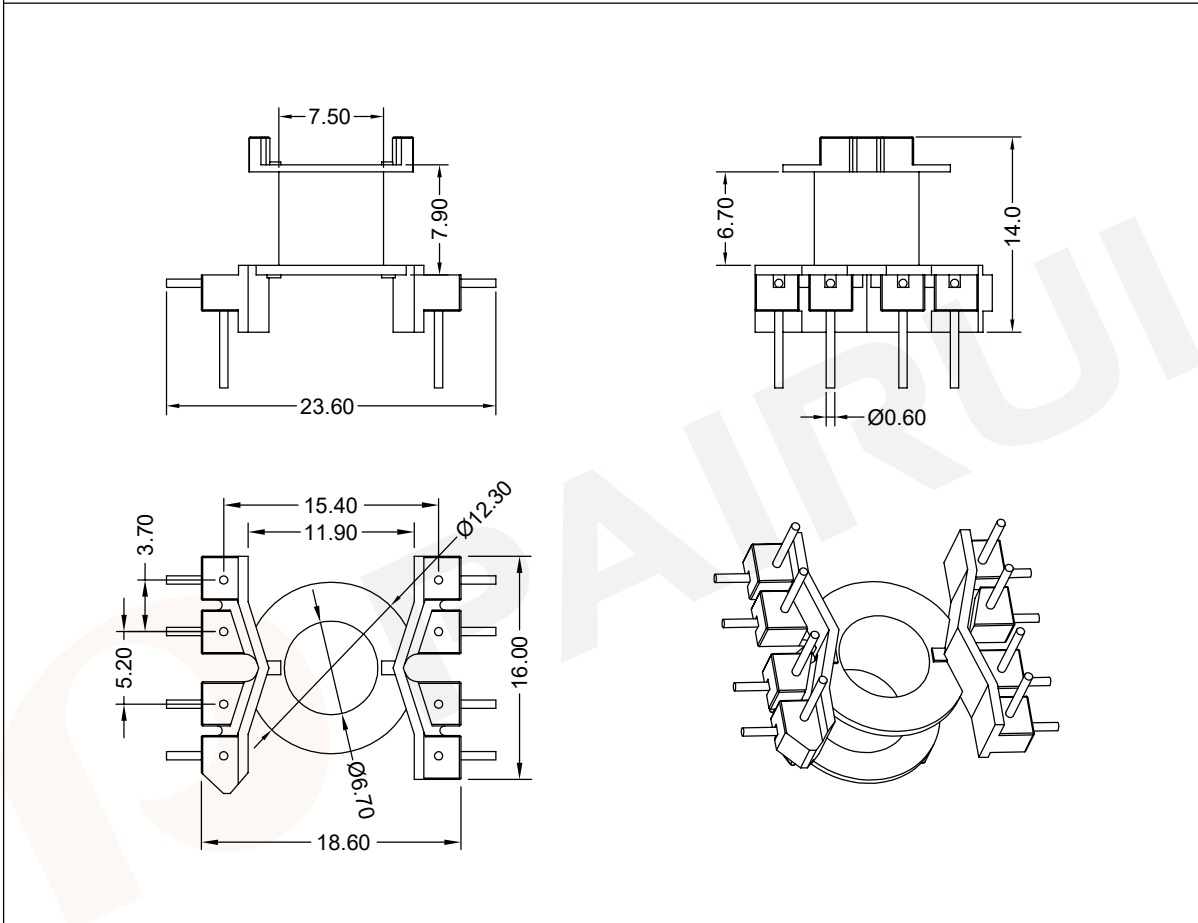

Winding data and area product for 8-pins RM6 coil former

NUMBER OF SECTIONS	WINDING AREA (mm <sup>2</sup> )	MINIMUM WINDING WIDTH (mm)	AVERAGE LENGTH OF TURN (mm)	AREA PRODUCT Ae x Aw (mm <sup>4</sup> )	TYPE NUMBER
1	15	6.70	31	525	RM-0605-1-1S-8P

Tolerances unless otherwise specified:  
 $0 < L \leq 4 \pm 0.10$     $4 < L \leq 16 \pm 0.20$   
 $16 < L \leq 45 \pm 0.30$     $45 \leq L \pm 0.40$   
 Pin Dim:  $\pm 0.05$    Thickness:  $\pm 0.20$    Pin Pitch:  $\pm 0.20$

Dimensions:  
(mm)



REMARK

Mould No.: RM0605-1

Bobbin material: PA66

Code No.: FAY01091

Available for Fuan core: RM6



Fuan Electronics

TEL :0086-514-87693589  
 EML :sales@fuantronics.net  
 WEB:www.fuantronics.net

Make: P.Xiao

Material Number: A4Q060510100

Checked: Beson. zhan

Document/Rev: 00

Approved: Anson. zhan

Date of Recognition: Oct./17/2019