

P/N: FACSCM1265-2R2M

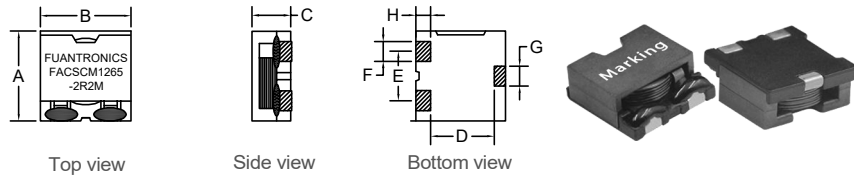

Outline Dimensions(Unit:mm)



	A	B	C	D	E	F	G	H
Max	±0.40	Max	REF	REF		REF	REF	
	13.5	12.5	6.50	9.00	6.90	2.0-2.6	2.60	2.00

Electronical Schematic

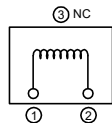

Suggested Pad layout

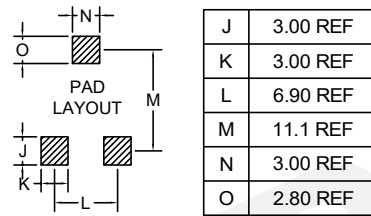

- \*\*\*Magnetic shielded structure: excellent resistance to electro magnetic interferenc(EMI).
- \*\*\*Assemblage design, sturdy structure.
- \*\*\*Small volume, high current, low magnetic loss, low ESR, small parasitic capacitance.
- \*\*\*Temperature rise current and saturation current is less influenced by environment.

Electrical Characteristics(@25°C)

Inductance 100KHz,0.1V	DC Resistor	Saturated current 22A	Temperature rise current 15.5A
2.20uH±20%	3.40mΩ Max	L(22A)=80%*L0A Typ	T≤40°C Typ

- \*\*\*Saturation current: the actual value of DC current when the inductance decrease 20% of its initial value.
- \*\*\*Temperature rise current: the actual value of DC current when the temperature rise is ΔT40°C(Ta=25°C).
- \*\*\*Operating Temperature: -40°C~+125°C. (Temperature rise included)
- \*\*\*Storage Temperature: -40°C~+125°C.
- \*\*\*Storage Humidity:RH10%~70%.

Saturation current VS temperature rise current curve:

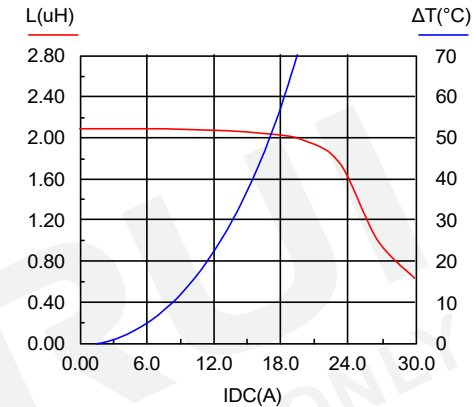

Recommended Soldering Temperature Graph.

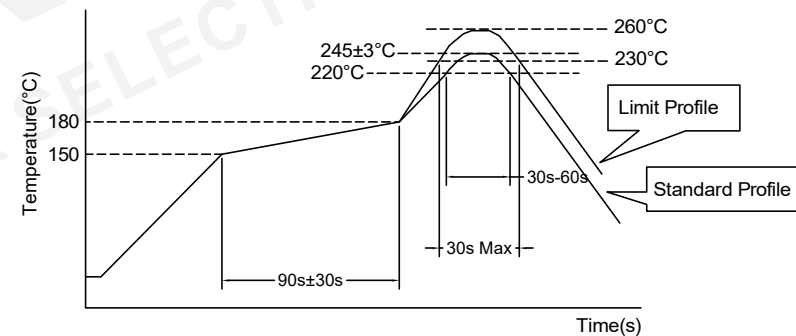

	Standard Profile	Standard Profile
Pre-heating	150~180°C,90s±30s	
Heating	above 220°C,30s-60s	above 240°C,30s Max
Peak temperature	245°C±3°C	260°C,10s
Cycle of reflow	2 times	