

**P3**      **T18\*10\*12.7**      **C/P**  
**Material**    **Core Size**    **Coating**  
 材质            品名            涂装

C=Epoxy. P=Parylene.

**Dimensions: (UNIT:mm)**

Dimensions(mm)			
Epoxy Coating Dimensions(mm)			
ΦD1	ΦD2	H	Wt(g/set)
18.0±0.40	10.0±0.30	12.7±0.30	9.25
19.10max	9.10min	13.8max	

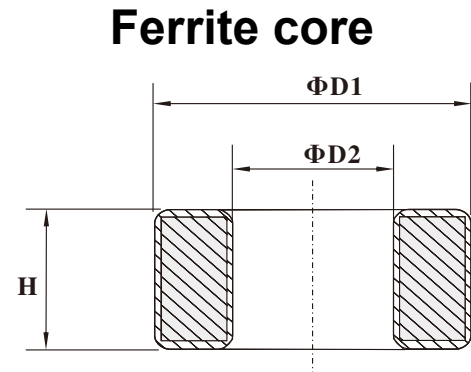
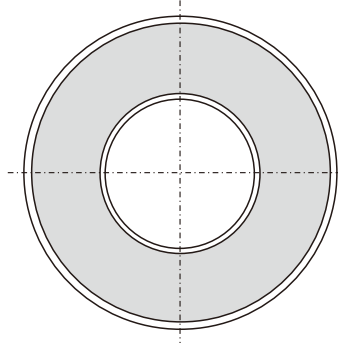

**Test Conditions**

AL: F=10.0KHz U=0.3V N=10Ts

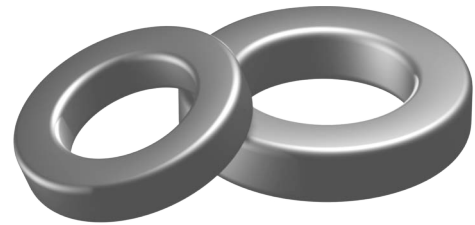

**Effective parameter**

	Ve(mm3)	Ae(mm2)	Le(mm)
	2040	49.4	41.5

**Coating**

The core are coated with epoxy, flame retardant in accordance with "UL 94V-0" file number E228348. The colour is green.

**Ring core data**

GRADE	AL(nH)	μi	TYPE NUMBER
P3	3600±25%	≈2300	T18/10/12.7/P3
H5K	7500±25%	≈5000	T18/10/12.7/H5K
H7K	10500±25%	≈7000	T18/10/12.7/H7K
H10K	14900±30%	≈10000	T18/10/12.7/H10K

**Note:**

- 1: Document is the property of FUAN Inc & is not allowed to be duplicated without authorization
- 2: RoHS compliant.

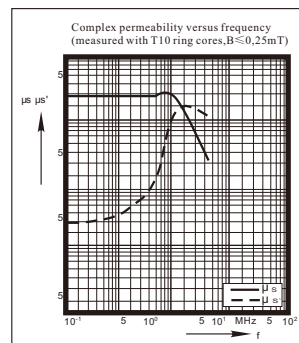

P3

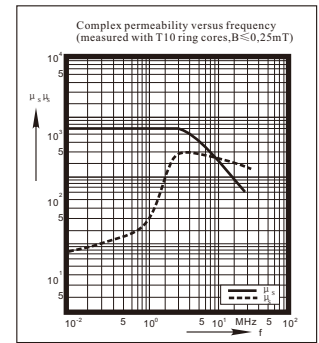

H5K

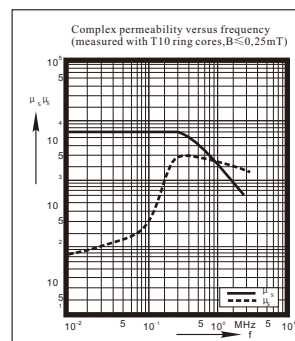

H7K

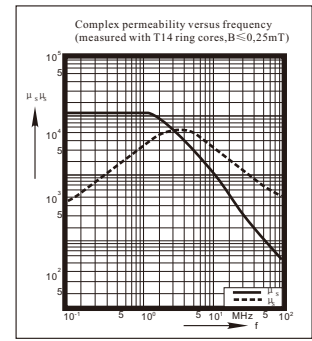

H10K