

P/N: FACSB0630-2R0M

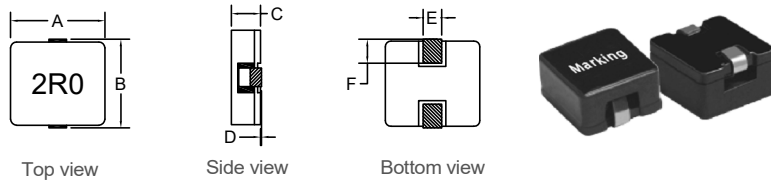

Outline Dimensions(Unit:mm)



| A | B | C | D | E | F |
|-------|-------|-------|-------|-------|-------|
| ±0.30 | ±0.50 | ±0.30 | | ±0.30 | ±0.30 |
| 6.90 | 7.00 | 3.00 | 0-0.2 | 1.20 | 1.80 |

Electronical Schematic

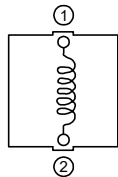

Suggested Pad layout

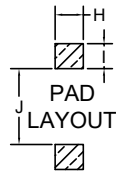

| | |
|---|----------|
| H | 2.50 REF |
| I | 2.50 REF |
| J | 2.50 REF |

Saturation current VS temperature rise current curve:

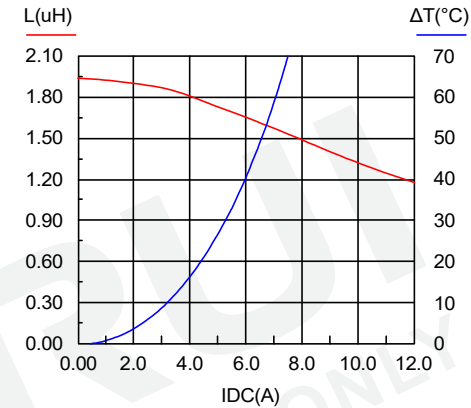

Recommended Soldering Temperature Graph.

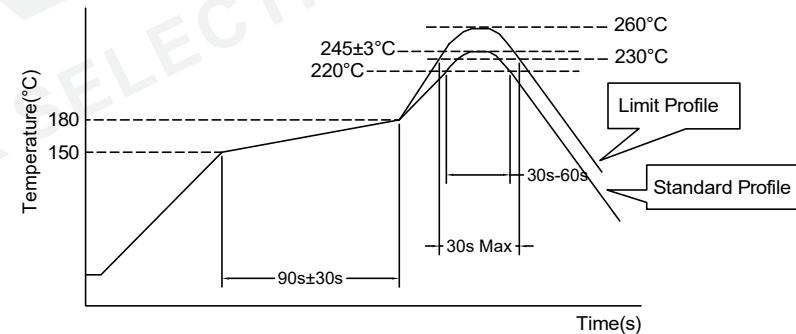

- ***Magnetic shielded structure: excellent resistance to electro magnetic interferenc(EMI).
- ***Flat wire winding, achieve a low D.C. Resistance.
- ***Low loss, high efficiency, wide application frequency and application scope.
- ***Lightweight design, save space, suitable for high density SMT.

Electrical Characteristics(@25°C)

| Inductance 100KHz,0.1V | DC Resistor | Saturated current 9A | Temperature rise current 6.5A |
|---------------------------|-------------|----------------------------|-------------------------------------|
| 2.00uH±20% | 15.6mΩ Max | L(9A)=70%*L0A Typ | T≤50°C Typ |

- ***Saturation current: the actual value of DC current when the inductance decrease 30% of its initial value.
- ***Temperature rise current: the actual value of DC current when the temperature rise is ΔT50°C(Ta=25°C).
- ***Operating Temperature: -40°C~+125°C.
(Temperature rise included)
- ***Storage Temperature: -40°C~+125°C.
- ***Storage Humidity:RH10%~70%.

| | Standard Profile | Standard Profile |
|------------------|---------------------|---------------------|
| Pre-heating | 150~180°C,90s±30s | |
| Heating | above 220°C,30s-60s | above 240°C,30s Max |
| Peak temperature | 245°C±3°C | 260°C,10s |
| Cycle of reflow | 2 times | 2 times |

| | | | | | | | | |
|-----|-------------|------|------|---|---|-----------------------------------|--|------------------|
| REV | DESCRIPTION | APPD | DATE | Tianchang Fuan Electronic Co Ltd www.fuantronics.net TEL: +86-550-7814888 FAX: +86-550-7831133 | Tolerances unless otherwise specified: (.X)±0.50 (.XX)±0.25 Unit of measurement: mm | Make: Qiumei.Liu | DRAWING TITLE HIGH CURRENT POWER INDUCTORS Material Number: A340630XS250 | Customer Name: |
| | | | | | | Checked: Beson. zhan | | Document/Rev: 00 |
| | | | | Approved: Anson. zhan | Specification Sheet: 1 of 1 | Date of Recognition: Jan./02/2020 | | |